



# CORDLESS CHAIN SAW

20 VOLT MAX\* | 10-INCH

## OPERATOR'S MANUAL

A Division of Snow Joe®, LLC

Model 20ViONLTE-CS10-RM

Form No. SJ-20ViONLTE-CS10-RM-880E-M-V1

# THANKS FOR YOUR PURCHASE OF A REMANUFACTURED PRODUCT.

To make sure you get the most out of your product, be sure to register online at

**sunjoe.com**

to enjoy full product support.

PASTE UPC LABEL HERE



# CORDLESS CHAIN SAW

20 VOLT MAX\* | 10-INCH

## OPERATOR'S MANUAL

A Division of Snow Joe®, LLC

Model 20ViONLTE-CS10-RM

Form No. SJ-20ViONLTE-CS10-RM-880E-M-V1

## IMPORTANT! Safety Instructions

### All Operators Must Read These Instructions Before Use

Read all the instructions contained in this manual. Keep this manual in a safe place, so that the information is available at all times. If you give the equipment to another person, make sure to provide these operating instructions. Basic safety precautions should always be followed to reduce the risk of fire, electric shock, and personal injury.

**⚠️ DANGER!** This indicates a hazardous situation, which, if not followed, will result in serious injury or death.

**⚠️ WARNING!** This indicates a hazardous situation, which, if not avoided, could result in serious injury or death.

**⚠️ CAUTION!** This indicates a hazardous situation, which, if not avoided, could result in minor or moderate injury.

### Intended Use

This cordless chain saw was designed and manufactured for trimming and pruning tree limbs and branches and for cutting smaller logs up to recommended 7.9 inch (20 cm), not to exceed a max cut of 9.5 in. (24 cm) in diameter depending on type of wood. All of the wooden objects intended to be cut with this chain saw should be no thicker than the guide bar's maximum cutting capabilities.

### Improper Use

Any other use differing from the above mentioned applications poses a serious hazard to the user and may damage both the tool and your personal property. Examples of improper use include, but are not limited to:

- Trimming hedges;
- Carving;
- Sectioning pallets, crates, and various packing materials;
- Sectioning furniture or other materials with nails, screws, or other metal components;
- Butchering meat;
- Using the machine to lift, move, or split objects;

- Using the machine while fastened to fixed supports.

Improper use of the machine will invalidate the warranty, relieve the manufacturer from all liabilities. The user will consequently be liable for all and any damage or injury to himself/herself or others.

## General Safety

**⚠️ WARNING!** When using electric/cordless yard tools, basic safety precautions should always be followed to reduce the risk of fire, electric shock, and personal injury, including the following:

1. **Keep guards in place** – Protective guards should be checked periodically to ensure they are properly fitted and in correct working order.
2. **Remove adjusting keys and wrenches** – Check that adjusting wrenches are removed from the saw before turning it on.
3. **Keep work area clean and well-lit** – Clear work area of branches and limbs after each cutting session. Cluttered areas invite accidents.
4. **Do not use in dangerous environments** – Do not use power tools in damp or wet locations.
5. **Do not use the chain saw in the rain.**
6. **Keep bystanders and children away** – All bystanders, including children and pets, should be kept a safe distance away from the work area.
7. **Do not force the tool** – It will do the job effectively and safely if it is used at the rate for which it was designed.
8. **Use the right tool** – Do not force the tool or any attachment on the tool to do a job for which they were not designed.
9. **Wear proper apparel** – Do not wear loose articles of clothing or jewelry since such items may get caught in moving parts. Use of heavy-duty rubber gloves, substantial non-skid footwear, and close-fitting clothing is recommended when working outdoors with power tools.
10. **Wear protective hair coverings to contain long hair.**
11. **Always wear safety glasses and ear defenders to provide eye and ear protection** – Everyday eyeglasses only have impact resistant lenses and do not provide the same protection as safety glasses.
12. **Wear face or dust masks** – If the cutting operation is dusty, the use of a face or dust mask specially designed to filter out microscopic particles is recommended.

13. **Do not overreach** – Keep proper footing and balance at all times.
14. **Maintain tools with care** – Keep tools sharp and clean for best and safest performance. Follow instructions for lubricating and changing accessories.
15. **Reduce the risk of unintentional starting** – Make sure not press the trigger switch before inserting the battery.
16. **Use recommended accessories** – Consult the owner's manual for recommended accessories. The use of improper accessories may cause risk of injury.
17. **Check for damaged parts** – Before each use, repair, or replace any guard or part that is damaged. In addition, check for alignment of moving parts, binding of moving parts, breakage of parts, and any other conditions that may affect the tool's operation.
18. **Never leave tool unattended while it is running** – Turn the power OFF by directly removing the battery. Do not leave the saw until the cutting bar comes to a complete stop.
19. **Avoid unintentional starting** – Do not carry the cordless chain saw with your finger on the switch.
20. **Do not grasp the exposed cutting blade or cutting edges when picking up or holding the saw** – Be sure to encase the cutting bar in its protective sheath when not in use.
21. **Stay alert** – Watch what you are doing. Use common sense. Do not operate the chain saw when you are tired.
22. **Store idle tool indoors** – When not in use, appliances should be stored indoors in a dry and high or locked-up place out of the reach of children.

## Chain Saw Safety Warnings

- Keep all parts of the body away from the saw chain when the chain saw is operating. Before you start the chain saw, make sure the saw chain is not contacting anything. A moment of inattention while operating the chain saw may cause entanglement of your clothing or body with the saw chain.
- Always hold the chain saw with your right hand on the rear handle and your left hand on the front handle. Holding the chain saw with a reversed hand configuration increases the risk of personal injury and should never be done.
- Wear safety glasses and hearing protection. If you are using the chain saw every day under normal conditions, you can be exposed to a noise level of 85 dB (A) or higher. Further protective equipment for head, hands, legs and feet is recommended. Adequate protective clothing will reduce personal injury by flying debris or accidental contact with the saw chain.
- Do not operate the chain saw in a tree. Operation of a chain saw while up in a tree may result in personal injury.

- Always keep proper footing and operate the chain saw only when standing on a fixed, secure and level surface. Slippery or unstable surfaces such as ladders may cause a loss of balance or control of the chain saw.
- When cutting a limb that is under tension, be cautious of spring back. When the tension in the wood fibers is released, the spring-loaded limb may strike the operator and/or throw the chain saw out of control.
- Use extreme caution when cutting brush and saplings. The slender material may catch the saw chain and be whipped toward you or pull you off balance.
- Carry the chain saw by the front handle with the chain saw switched off and away from your body. When transporting or storing the chain saw, always fit the guide bar cover. Proper handling of the chain saw will reduce the likelihood of accidental contact with the moving saw chain.
- Follow instructions for lubricating, chain tensioning and changing accessories. An improperly tensioned or poorly lubricated chain may either break or increase the chance for kickback.
- Keep handles dry, clean and free from oil and grease. Greasy, oily handles are slippery and can cause loss of control.
- Cut wood only. Do not use the chain saw for any other purpose. For example, do not use the chain saw to cut plastic, masonry or non-wood building materials. Using the chain saw in these incorrect ways could result in serious damage to you and your tool.

## Battery & Charger Safety Instructions

We pay a great deal of attention to the design of every battery pack to ensure that we supply you with batteries that are safe, durable and have a high energy density. The battery cells have a wide range of safety devices. Each individual cell is initially formatted and its electrical characteristic curves are recorded. This data is then used exclusively to be able to assemble the best possible battery packs.

Despite all the safety precautions, caution must always be exercised when handling batteries. The following points must be obeyed at all times to ensure safe use. Safe use can only be guaranteed if undamaged cells are used. Incorrect handling of the battery pack can cause cell damage.

**IMPORTANT!** Analyses confirm that incorrect use and poor care of high-performance batteries are the main factors responsible for personal and/or product damage.

 **WARNING!** Use only approved replacement batteries; other batteries may damage the chain saw and cause it to malfunction, which can lead to serious personal injury.

**⚠ CAUTION!** To reduce the risk of injury, charge the EcoSharp® LITE iBAT20-LTE lithium-ion battery pack only in its designated lithium-ion charger, the iCHRG20. Other types of chargers present risk of fire, personal injury and damage. Do not wire a battery pack to a power supply plug or car cigarette lighter. Such misuse will permanently disable or damage the battery pack.

- **Avoid dangerous environments** – Do not charge the battery pack in rain, snow or in damp or wet locations. Do not use the battery pack or charger in the presence of explosive atmospheres (gaseous fumes, dust or flammable materials) because sparks may be generated when inserting or removing the battery pack, which could lead to a fire.
- **Charge in a well-ventilated area** – Do not block the charger vents. Keep them clear to allow for proper ventilation. Do not allow smoking or open flames near a charging battery pack. Vented gases may explode.

**NOTE:** The safe temperature range for the battery is 32°F (0°C) to 113°F (45°C). Do not charge the battery outside in freezing weather; charge it at room temperature.

- **Maintain charger cord** – When unplugging the charger, pull the plug, not the cord, from the receptacle to reduce the risk of damage to the electrical plug and cord. Never carry the charger by its cord or yank it by the cord to disconnect it from the receptacle. Keep the cord away from heat, oil and sharp edges. Make sure the cord will not be stepped on, tripped over or subjected to damage or stress when the charger is in use. Do not use the charger with a damaged cord or plug. Replace a damaged charger immediately.
- **Do not use an extension cord unless it is absolutely necessary** – Using the wrong, damaged or improperly wired extension cord poses a risk of fire and electric shock. If an extension cord must be used, plug the charger into a properly wired 16 gauge or larger extension cord with the female plug matching the male plug on the charger. Make sure that the extension cord is in good electrical condition.
- **Charger iCHRG20 is rated for 120 volt AC only** – The charger must be plugged into an appropriate receptacle.
- **Use only recommended attachments** – Use of an attachment not recommended or sold by the battery charger or battery pack manufacturer may result in risk of fire, electric shock or personal injury.
- **Unplug charger when not in use** – Make sure to remove battery packs from unplugged chargers.

**⚠ WARNING!** To reduce the risk of electric shock, always unplug the charger before performing any cleaning or maintenance. Do not allow water to flow into the charger. Use a Ground Fault Circuit Interrupter (GFCI) to reduce shock hazards.

- **Do not burn or incinerate battery packs** – Battery packs may explode, causing personal injury or damage. Toxic fumes and materials are created when battery packs are burned.

- **Do not crush, drop or damage battery packs** – Do not use the battery pack or charger if they have sustained a sharp blow, been dropped, run over or have been damaged in any way (i.e. pierced with a nail, hit with a hammer, stepped on, etc.).
- **Do not disassemble** – Incorrect reassembly may pose a serious risk of electric shock, fire or exposure to toxic battery chemicals. If the battery or charger are damaged, please contact an authorized Snow Joe® + Sun Joe® dealer or call the Snow Joe® + Sun Joe® customer service center at 1-866-SNOWJOE (1-866-766-9563).
- **Battery chemicals cause serious burns** – Never let a damaged battery pack contact the skin, eyes or mouth. If a damaged battery pack leaks battery chemicals, use rubber or neoprene gloves to safely dispose of it. If skin is exposed to battery fluids, wash the affected area with soap and water and rinse with vinegar. If eyes are exposed to battery chemicals, immediately flush with water for 20 minutes and seek medical attention. Remove and dispose of contaminated clothing.
- **Do not short circuit** – A battery pack will short circuit if a metal object makes a connection between the positive and negative contacts on the battery pack. Do not place a battery pack near anything that may cause a short circuit, such as paper clips, coins, keys, screws, nails and other metallic objects. A short-circuited battery pack poses a risk of fire and severe personal injury.
- **Store your battery pack and charger in a cool, dry place** – Do not store the battery pack or charger where temperatures may exceed 104°F (40°C), such as in direct sunlight or inside a vehicle or metal building during the summer.

## Information about the battery

1. The battery pack supplied with your cordless chain saw is only partially charged. The battery pack has to be charged completely before you use the tool for the first time.
2. For optimum battery performance, avoid low discharge cycles by charging the battery pack frequently.
3. Store the battery pack in a cool place, ideally at 77°F (25°C) and charged to at least 40%.
4. Lithium-ion batteries are subject to a natural aging process. The battery pack must be replaced at the latest when its capacity falls to just 80% of its capacity when new. Weakened cells in an aged battery pack are no longer capable of meeting the high power requirements needed for the proper operation of your chain saw, and therefore pose a safety risk.
5. Do not throw battery packs into an open fire as this poses a risk of explosion.
6. Do not ignite the battery pack or expose it to fire.
7. Do not exhaustively discharge batteries. Exhaustive discharge will damage the battery cells. The most

common cause of exhaustive discharge is lengthy storage or non-use of partially discharged batteries. Stop working as soon as the performance of the battery falls noticeably or the electronic protection system triggers. Place the battery pack in storage only after it has been fully charged.

8. Protect batteries and the tool from overloads. Overloads will quickly result in overheating and cell damage inside the battery housing even if this overheating is not apparent externally.
9. Avoid damage and shocks. Immediately replace batteries that have been dropped from a height of more than one meter or those that have been exposed to violent shocks, even if the housing of the battery pack appears to be undamaged. The battery cells inside the battery may have suffered serious damage. In such instances, please read the waste disposal information for proper battery disposal.
10. If the battery pack suffers overloading and overheating, the integrated protective cutoff will switch off the equipment for safety reasons.  
**IMPORTANT!** Do not press the ON/OFF switch any more if the protective cut-off has been activated. This may damage the battery pack.
11. Use only original battery packs. The use of other batteries poses a fire risk and may result in injuries or an explosion.

## Information about the charger and the charging process

1. Please check the data marked on the rating plate of the battery charger. Be sure to connect the battery charger to a power supply with the voltage marked on the rating plate. Never connect it to a different mains voltage.
2. Protect the battery charger and its cord from damage. Keep the charger and its cord away from heat, oil and sharp edges. Have damaged cords repaired without delay by a qualified technician at an authorized Snow Joe® + Sun Joe® dealer or call the Snow Joe® + Sun Joe® customer service center at 1-866-SNOWJOE (1-866-766-9563).
3. Electrical plugs must match the outlet. Never modify the plug in any way. Do not use any adapter plugs with grounded appliances. Unmodified plugs and matching outlets will reduce the risk of electric shock.
4. Keep the battery charger, battery pack(s) and the cordless tool out of the reach of children.
5. Do not use the supplied battery charger to charge other cordless tools.
6. During periods of heavy use, the battery pack will become warm. Allow the battery pack to cool to room temperature before inserting it into the charger to recharge.
7. Do not overcharge batteries. Do not exceed the maximum charging times. These charging times only apply to discharged batteries. Frequent insertion of a charged or partially charged battery pack will result in overcharging and cell damage. Do not leave batteries in the charger for days on end.

8. Never use or charge batteries if you suspect that it has been more than 12 months since the last time they were charged. There is a high probability that the battery pack has already suffered dangerous damage (exhaustive discharge).
9. Charging batteries at a temperature below 50°F (10°C) will cause chemical damage to the cells and may cause a fire.
10. Do not use batteries that have been exposed to heat during the charging process, as the battery cells may have suffered dangerous damage.
11. Do not use batteries that have suffered curvature or deformation during the charging process or those that exhibit other atypical symptoms (gassing, hissing, cracking, etc.)
12. Never fully discharge the battery pack (maximum recommended depth of discharge is 80%). A complete discharge of the battery pack will lead to premature aging of the battery cells.

## Protection from environmental influences

1. Wear suitable work clothes. Wear safety goggles.
2. Protect your cordless tool and the battery charger from moisture and rain. Moisture and rain can cause dangerous cell damage.
3. Do not use the cordless tool or the battery charger near vapors and flammable liquids.
4. Use the battery charger and cordless tools only in dry conditions and at an ambient temperature of 50 – 104°F (10 – 40°C).
5. Do not keep the battery charger in places where the temperature is liable to reach over 104°F (40°C). In particular, do not leave the battery charger in a car that is parked in the sunshine.
6. Protect batteries from overheating. Overloads, overcharging and exposure to direct sunlight will result in overheating and cell damage. Never charge or work with batteries that have been overheated – replace them immediately, if possible.
7. Store the charger and your cordless tool only in dry locations with an ambient temperature of 50 – 104°F (10 – 40°C). Store your lithium-ion battery pack in a cool, dry place at a temperature of 50 – 68°F (10 – 20°C). Protect the battery pack, charger and cordless tool from humidity and direct sunlight. Only place fully charged batteries in storage (charged to at least 40%).
8. Prevent the lithium-ion battery pack from freezing. Battery packs that were stored below 32°F (0°C) for more than 60 minutes must be discarded.
9. When handling batteries, be wary of electrostatic charge. Electrostatic discharges can damage the electronic protection system and the battery cells. Avoid electrostatic charging and never touch the battery poles.

## Kickback

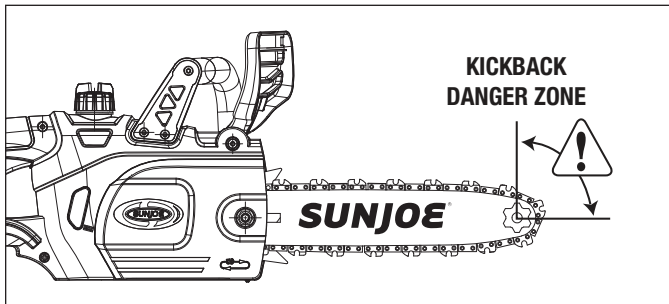

**⚠ WARNING!** Kickback may occur when the nose or tip of the guide bar touches an object, or when the wood closes in and pinches the saw chain in the cut.

**AVOID CONTACTING THE GUIDE BAR TIP WITH ANY OBJECT.** In some cases, when the tip makes contact with an object, it may cause a fast reverse reaction, kicking the guide bar up and back towards the operator. Pinching the saw chain along the top of the guide bar may also push the guide bar rapidly back towards the operator. Either of these reactions may cause you to lose control of the saw, which could result in serious personal injury.

- Maintain a firm grip (right hand on the rear handle and left hand on the front handle with thumbs and fingers encircling the respective handles) and position your body and arms to allow you to resist kickback forces. Kickback forces can be controlled by the operator if proper precautions are taken. Do not let go of the chain saw.
- Keep all guards in place on the machine. Make sure they are in proper working order.
- Do not overreach. Do not cut above shoulder height. This helps prevent unintended tip contact and enables better control of the unit in unexpected situations.
- Keep solid footing and balance at all times.
- Never try cutting through two branches at the same time. Only cut one at a time.
- Do not bury the guide bar nose or try to cut by boring the guide bar nose into the wood.
- Watch for shifting of wood or other forces that may pinch the chain.
- Use extreme caution when re-entering a previous cut.
- Use the low-kickback chain and guide bar supplied with this cordless chain saw. Only use genuine Snow Joe® + Sun Joe® replacement parts designed specifically for use with this cordless chain saw.
- Never use a dull or loose chain. Keep the chain sharp and properly tensioned.
- Follow the manufacturer's sharpening and maintenance

instructions for the saw chain. Decreasing the depth gauge height can lead to increased kickback.

















- Always observe the safety regulations and follow the correct sawing techniques.
- Ensure safe carrying of the unit. Whenever the machine is to be handled or transported, you must:
  - Switch off the motor and wait for the chain to come to a complete stop;
  - Mount the guide bar cover;
  - Hold the machine using the hand grips and position the bar in the opposite direction to that used during operation.

When using a vehicle to transport the machine, fasten the tool firmly and position it so that it is not a danger to any passengers.

- Before cutting, pruning, or delimiting for the first time, make sure:
  - You have been specifically trained to use this type of equipment;
  - You have carefully read the safety regulations and user instructions contained in this manual;
  - You practice first on logs on the ground or attached to trestles/saw horses, in order to get familiar with the machine and the proper cutting techniques.

# Safety Symbols

The following table depicts and describes safety symbols that may appear on this product. Read, understand, and follow all instructions on the machine before attempting to assemble and operate.

Symbols	Descriptions	Symbols	Descriptions
	<b>READ THE OPERATOR'S MANUAL(S)</b> – Read, understand and follow all instructions in the user manual(s) before attempting to assemble and operate.	 	<b>DANGER! ROTATING BLADES</b> – Keep hands and feet away from openings while the saw is running.
	<b>SAFETY ALERT</b> – Indicates a precaution, a warning or a danger.		<b>WEAR EYE AND HEARING PROTECTION</b> – For protection against injury, wear ear defenders and safety goggles.
	<b>WARNING!</b> Do not expose the unit to rain or wet conditions.		The rotating part will continuously run for several seconds after you turn off the machine.
	Wear safety gloves during use to protect hands.		Wear safety footwear at all times to provide protection against objects that may accidentally fall on feet.
 	<b>CAUTION!</b> Avoid contacting the guide bar tip with any object. Tip contact may cause the guide bar to move suddenly upward and backwards, which may cause serious injury to the user.	 	<b>WARNING!</b> Two hands are always to be used when operating the chain saw.
	Keep bystanders and children a safe distance away.		Correct direction of cutting teeth.
	The rotating part will continuously run for several seconds after you turn off the machine.		Indoor use only. Only use battery charger indoors.

# Know Your Cordless Chain Saw

Read the owner's manual and safety instructions carefully before operating cordless chain saw. Compare the illustration below to the cordless chain saw in order to familiarize yourself with the location of the various controls and adjustments. Save this manual for future reference.

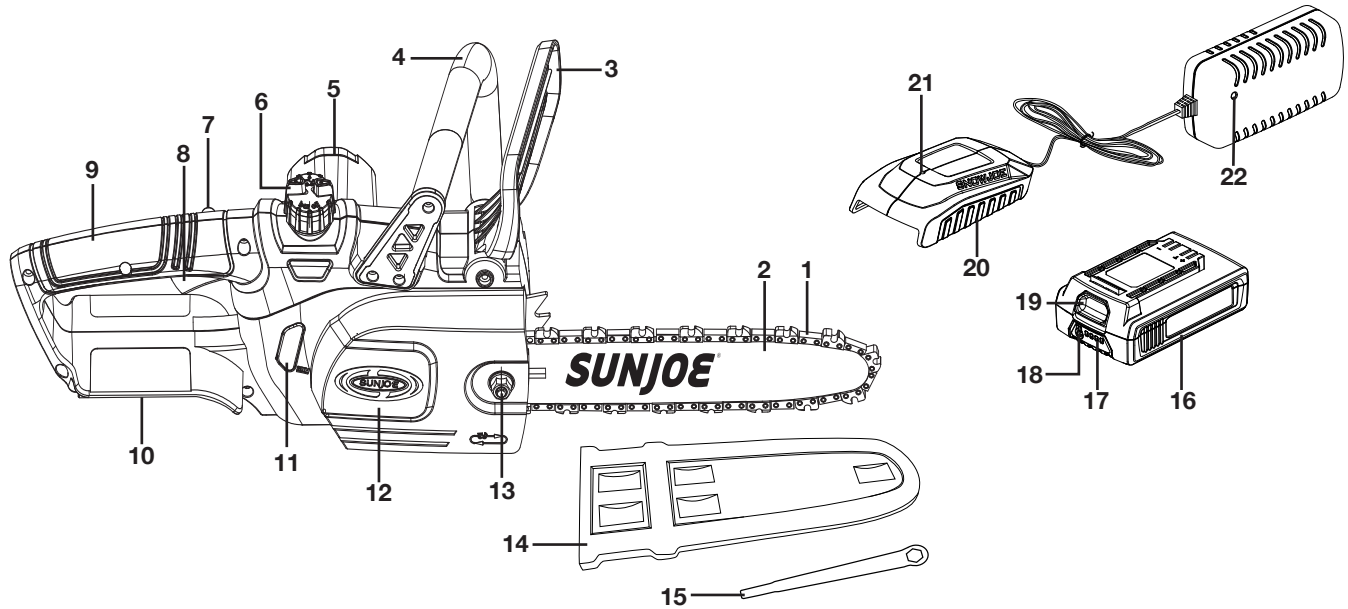

- |                                |   |
|--------------------------------|---|
| 1. 10 in. cutting chain        | 12. Chain/sprocket end cover                        |
| 2. 10 in. guide bar            | 13. End cover nut                                   |
| 3. Front hand guard            | 14. Cutting bar sheath                              |
| 4. Front hand grip             | 15. Hex key wrench/blade screwdriver                |
| 5. Motor                       | 16. EcoSharp® LITE lithium-ion battery (iBAT20-LTE) |
| 6. Oil tank cap                | 17. Battery charge level indicator                  |
| 7. Safety lock button          | 18. Push button for battery indicator               |
| 8. Trigger switch              | 19. Push lock button                                |
| 9. Rear handle grip            | 20. EcoSharp® lithium-ion charger (iCHR20)          |
| 10. Battery compartment        | 21. Charger base indicator                          |
| 11. Oil level indicator window | 22. Charger plug indicator                          |

## Technical Data

Battery Voltage* .....	20 V D.C.	Cutting Thickness.....	Max: 9.5 in. (24.1 cm) Recommended: 8.5 in. (21.6 cm)
Battery Capacity.....	2.0 Ah	Oil Tank Capacity .....	3.4 fl oz (100 ml)
Charging Time Max .....	70 min	Weight (chain saw alone).....	5.08 lbs (2.3 kg)
Battery Run Time Max.....	10 min/up to 18 cuts**	Weight .....	5.7 lbs (2.6 kg) (chain saw with battery installed)
No Load Speed .....	2300 rpm	Weight .....	6.4 lbs (2.9 kg) (chain saw with battery and charger)
Motor .....	200 W brush motor		
Bar Chain Length .....	10 in. (25.4 cm)		

\*Initial no-load voltage, when fully charged, peaks at 21 volts; nominal voltage under typical load is 20 volts. \*\*Based on 5.9" diameter cut.



# Unpacking

## Carton Contents

- Cordless chain saw
- 10 in. (25.4 cm) guide bar
- 10 in. (25.4 cm) cutting chain
- 20 V EcoSharp® LITE battery
- 20 V EcoSharp® battery charger
- Hex key wrench/blade screwdriver
- Cutting bar sheath
- Manuals with registration card

1. Carefully remove the cordless chain saw and check to see that all of the above items are supplied.
2. Inspect the product carefully to make sure no breakage or damage occurred during shipping. If you find damaged or missing parts, DO NOT return the unit to the store. Please call the Snow Joe® + Sun Joe® customer service center at 1-866-SNOWJOE (1-866-766-9563).

**NOTE:** Do not discard the shipping carton and packaging material until you are ready to use your new cordless chain saw. The packaging is made of recyclable materials. Properly dispose of these materials in accordance with local regulations.

**IMPORTANT!** The equipment and packaging material are not toys. Do not let children play with plastic bags, foils, or small parts. These items can be swallowed and pose a suffocation risk!

## Assembly

**⚠ WARNING!** Always wear heavy-duty gloves when handling the bar and chain. Mount the bar and chain very carefully so as not to impair the safety and efficiency of the machine. If in doubt, contact an authorized Snow Joe® + Sun Joe® dealer or call the Snow Joe® + Sun Joe® customer service center at 1-866-SNOWJOE (1-866-766-9563).

**⚠ WARNING!** Unpacking and assembly should be completed on a flat and stable surface, with adequate space for moving the machine and its packaging.

**⚠ DANGER!** Never start the motor before installing the guide bar, chain, and chain cover. Without all these parts in place, the clutch can fly off or explode, exposing the user to potentially serious injuries.

**⚠ WARNING!** To avoid serious personal injury, read and understand all safety instructions provided.

**⚠ WARNING!** Before performing any maintenance, make sure the battery is removed from the battery compartment.

Failure to heed this warning could result in serious personal injury.

## Installing/Replacing the Guide Bar and Chain

Tools and supplies required:

- Dual-tipped hex key wrench/blade screwdriver (supplied)
- Heavy-duty work gloves

**NOTE:** When replacing the guide bar and chain, use only identical replacement parts. Make sure the battery is not inserted in the compartment before proceeding with installation.

1. Using the supplied hex key wrench, unscrew the end cover nut and remove the chain/sprocket end cover (Figs. 1 & 2).

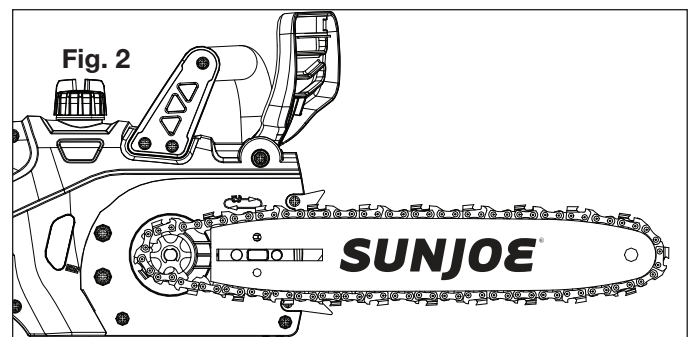
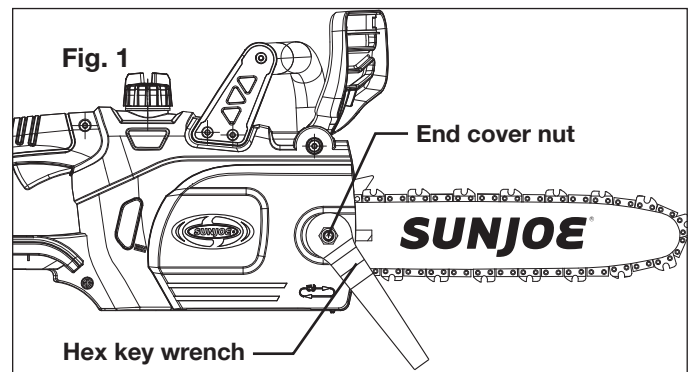

2. Remove the cutting bar and chain from the mounting surface (Fig. 3).

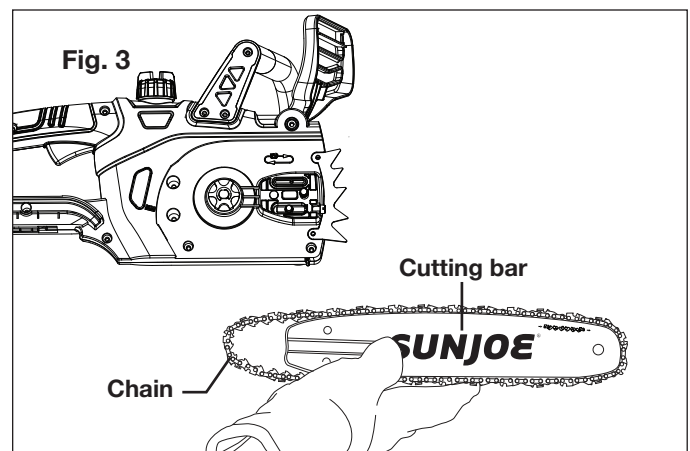

- Remove the old chain from the bar.
- Lay out the new saw chain in a loop and straighten any kinks. **THE SHARP SIDE OF THE TEETH MUST FACE AWAY FROM YOU IN THE DIRECTION OF THE CHAIN ROTATION INDICATED ON THE GUIDE BAR** →  →. If the teeth face backwards, turn the loop over (Fig. 4).

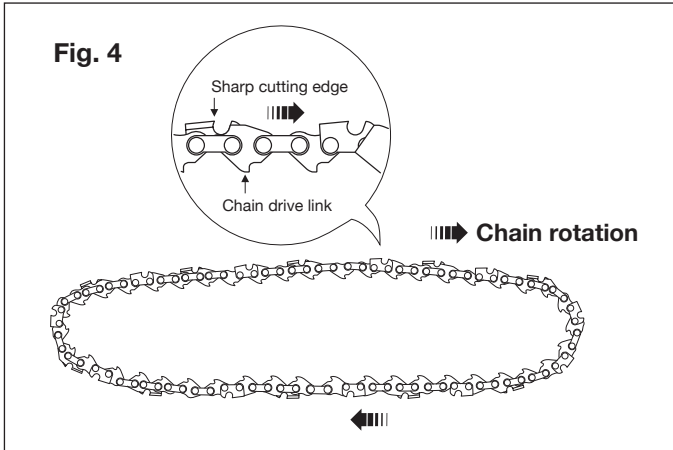

- Starting at the tip, mount the chain drive links into the bar groove, leaving a loop at the back of the bar. The chain will loosely fit until it is placed on the sprocket (Figs. 5 & 6).

**NOTE:** Make certain of the direction of the chain →  →. If the chain is mounted backwards, the saw will vibrate abnormally and will not cut.

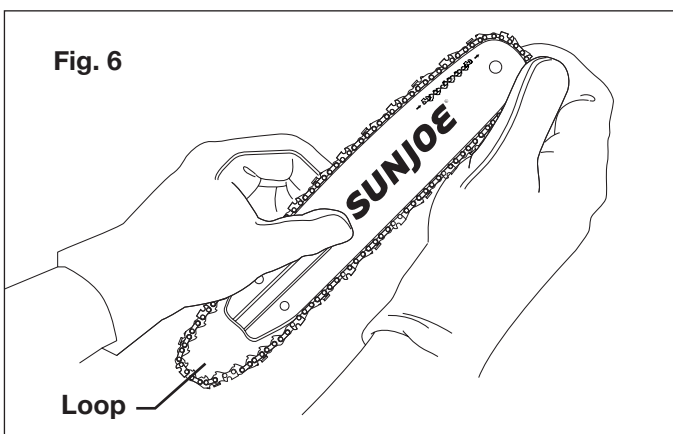
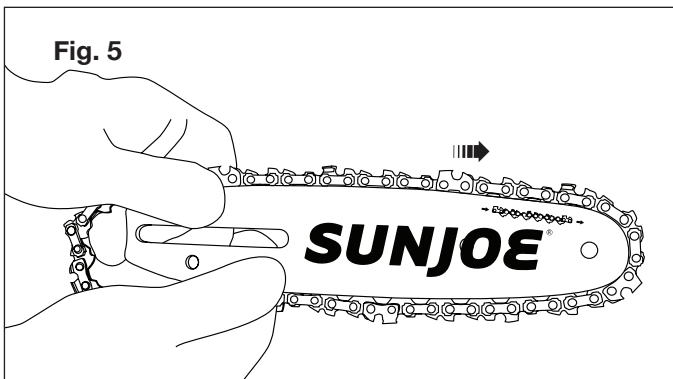

- Hold the chain in position on the bar and place the loop around the sprocket. Fit the bar flush against the mounting surface so that the bar studs are in the long slot of the bar and the adjusting pin is in the chain tension pin hole (Fig. 7).

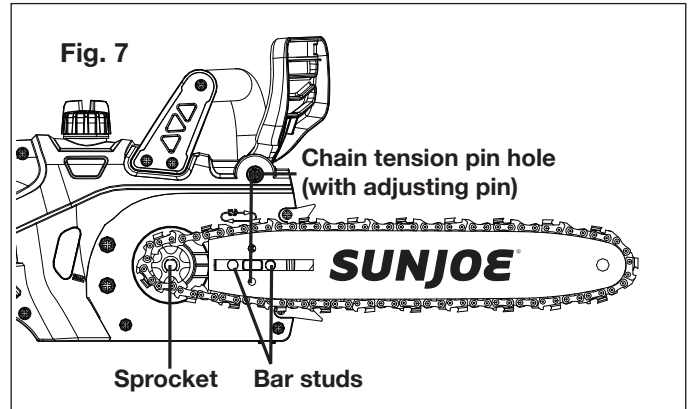

- Adjust the chain tension as needed by adjusting the chain tensioner screw with the supplied flat-tip blade screwdriver. Make sure to align the chain tensioner screw with the pin hole (Fig. 8).

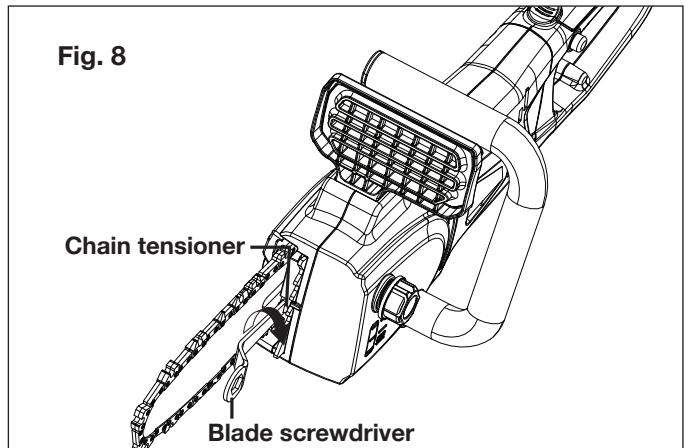

- Replace the chain/sprocket end cover. Tighten the end cover nut, but leave the bar free to move for tension adjustment.
- Remove all slack from the chain by turning the chain tensioner screw clockwise until the chain seats snugly against the bar with the drive links in the bar groove (Fig. 9).

**NOTE:** The chain is correctly tensioned when there is no sag on the underside of the guide bar; the chain is snug, but can be rotated by hand without binding. For more information on chain tensioning, see the maintenance section beginning on pg. 18.

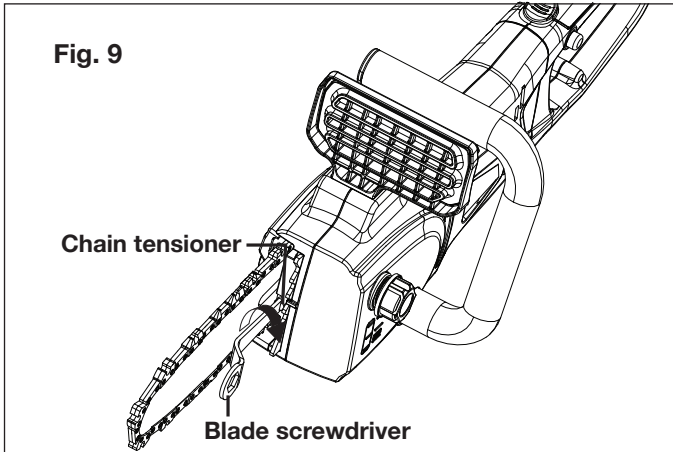

**NOTE:** You must fill the chain oil tank with bar and chain oil before using your chain saw.

## Adjusting the Chain Tension

1. Loosen the end cover nut until it is hand-tight. Use the flat-tip blade screwdriver to turn the chain tensioner screw clockwise to tension the chain. A cold chain will be correctly tensioned when there is no slack on the underside of the guide bar; the chain is snug, but it can be turned by hand without binding (Fig. 10).

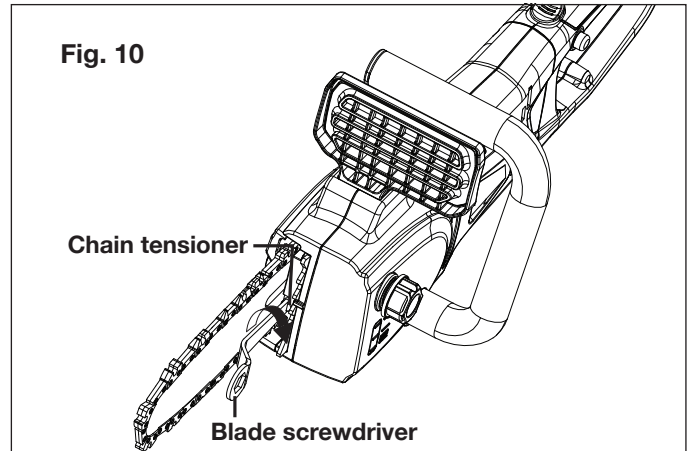

10. Tighten the end cover nut using the hex key wrench .

**NOTE:** If the chain is too tight, it will not rotate. Loosen the end cover nut slightly and turn the chain tensioner 1/4 turn counterclockwise. Lift the tip of the guide bar up and retighten the end cover nut. Ensure that the chain can be rotated by hand without binding.

**NOTE:** A new chain tends to stretch; check the chain tension frequently, and adjust tension as required.

## Preparing To Work

### Checking the Machine

**⚠ WARNING!** Before performing any checks, adjustments, repairs or maintenance on the machine, make sure the battery is not inserted in the compartment.

**⚠ CAUTION!** The chain will continue to run for several seconds after turning off the tool.

Before starting work please:

- Check that all the screws on the machine and the guide bar are tightly fastened;
- Check that the chain is tensioned correctly, sharp and there are no signs of any damage;
- Check that hand grips and protection devices are clean and dry, correctly mounted and securely fastened to the machine;
- Check that the chain brake is working efficiently;
- Check that the trigger switch and the safety button move freely without forcing and return automatically and rapidly back to their neutral positions;
- Check that the trigger switch remains locked until the safety button is pressed;
- Make sure the cooling air vents are not clogged with sawdust or debris;
- Check that the chain's oil level is not below the "MIN" level mark; if necessary, top up the oil to 1 cm from the rim of the filler.

2. The tension is correct when the drive links on the chain do not slip out of the chain guide on the bar when the chain is pulled up from the middle of the bar (Fig. 11).

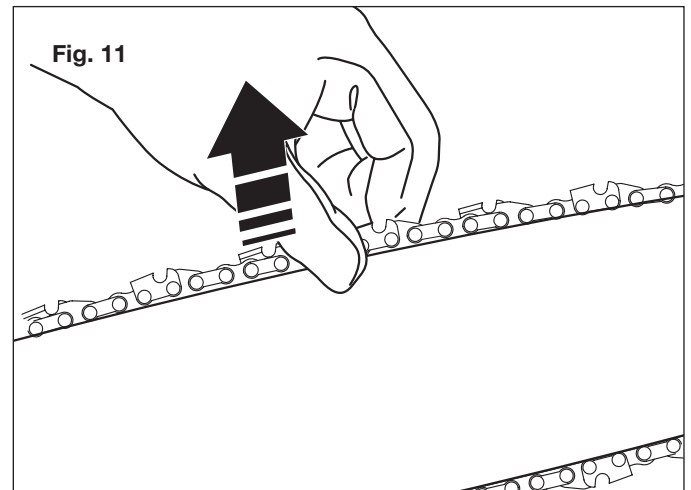

Loosen the brake by pressing both the switch and the safety button. Using a screwdriver, run the chain along the guide to check that it moves smoothly.

## Chain Lubricant

**IMPORTANT!** Only use a good quality bar and chain oil designed specifically for use with chain saws to ensure optimal lubrication of the cutting parts. Do not use oil containing impurities to avoid clogging the tank filter and permanently damaging the oiler.

**IMPORTANT!** The chain lubricating oil is bio-degradable. The use of mineral oil or engine oil can have a serious impact on the environment. It is essential that you use good quality oil to lubricate the cutting parts effectively. Used or poor quality oil does not guarantee good lubrication and reduces the lifespan of the chain and bar.

**IMPORTANT!** Before each machine use, the oil level should be checked and topped up to 1 cm from the rim of the filler. To fill the oil tank, remove the oil tank cap and add the recommended bar and chain oil. The oil level must not drop below the "MIN" level mark, as indicated on the oil level window (Fig. 12).

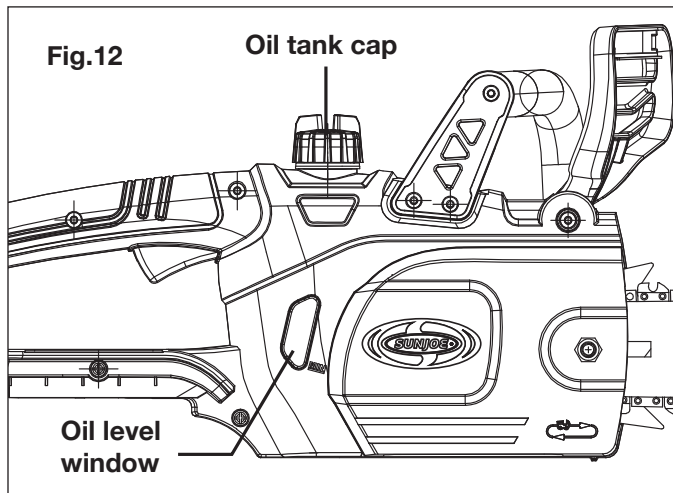

## Battery Pack Operation

The equipment is powered by a lithium-ion battery. The battery pack is completely sealed and maintenance free.

### Battery Charge Level Indicator

The battery pack is equipped with a push button for checking the charge level. Simply press the push button to read off the battery charge level from the LEDs of the battery indicator:

- All 4 level monitoring LEDs are lit: Battery charge level is maximum.
- 3 level monitoring LEDs are lit: Battery charge level is high.
- 2 level monitoring LEDs are lit: Battery charge level is decreasing. Stop work as soon as possible.

- 1 level monitoring LED is lit: Battery is flat. Stop work IMMEDIATELY and charge the battery. Otherwise the battery's service life will be greatly shortened.

Lights	Light Indicators
	Charge level button
	The battery is at 25% capacity and requires charging
	The battery is at 50% capacity and requires charging soon
	The battery is at 75% capacity
	The battery is at full capacity

**NOTE:** If the charge level button does not appear to be working, place the battery pack on the charger and charge as needed.

Immediately after using the battery pack, the charge level button may display a lower charge than it will if checked a few minutes later. The battery cells "recover" some of their charge after resting.

## Charger Operation

**⚠ WARNING!** Charge only EcoSharp® LITE iBAT20-LTE lithium-ion battery packs in compatible EcoSharp® iCHRG20 lithium-ion battery chargers. Other types of batteries may cause personal injury and damage.

To reduce the risk of electric shock, do not allow water to flow into the charger.

### When to Charge the EcoSharp® LITE iBAT20-LTE Lithium-Ion Battery

**NOTE:** The EcoSharp® LITE iBAT20-LTE lithium-ion battery packs do not develop a "memory" when charged after only a partial discharge. Therefore, it is not necessary to run down the battery pack before placing it into the charger.

- Use the battery charge indicator lights to determine when to charge your EcoSharp® LITE iBAT20-LTE lithium-ion battery pack.
- You can "top-off" your battery pack's charge before starting a big job or after a long day of use.

## Charging the Battery

1. Pull the push lock button on the battery to pull the battery pack out of the equipment (Fig. 13).

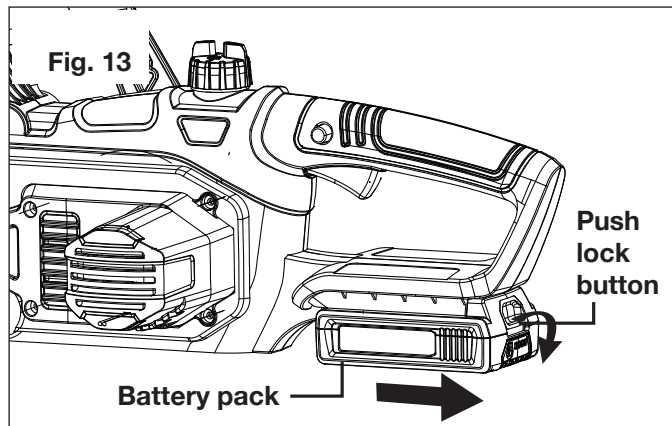

2. Check that the mains voltage is the same as that marked on the rating plate of the battery charger. Then, insert the charger's plug into the electrical wall outlet. When you plug in the charger, the light on the charging plug will illuminate red. When fully charged, the light will illuminate green (Fig. 14).

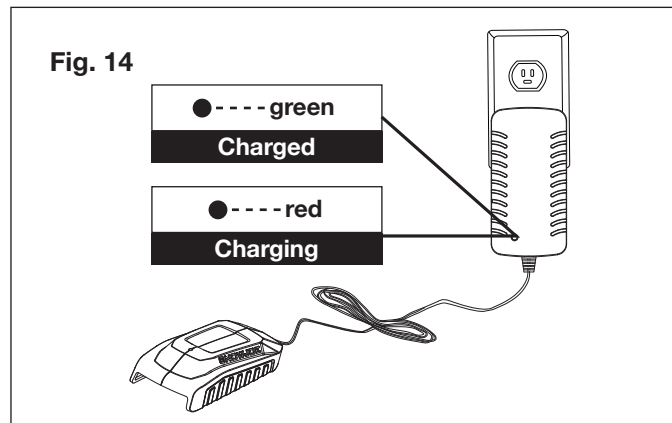

3. Place the battery pack into the charger by sliding the pack as shown to lock it into position. When you insert the battery into the charger, the light on the charging base will illuminate red to indicate that the battery is charging (Fig. 15).

4. When the charger base light turns green, the battery is fully charged (Fig. 15).

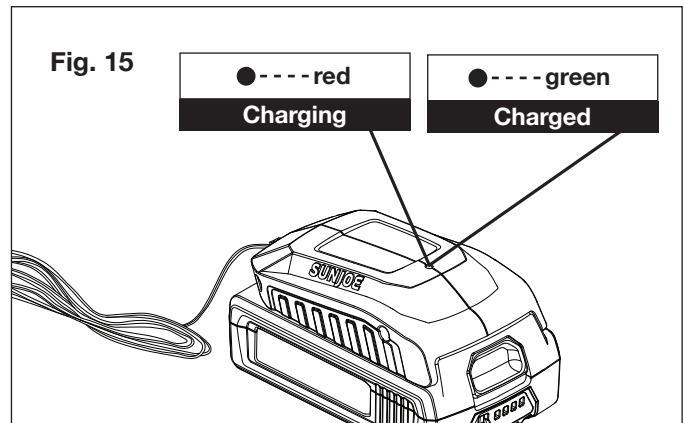

**NOTE:** If the charger plug light remains green while the charger base light alternately flashes red and green, this indicates a temperature abnormality (i.e. that the battery pack is either too hot or too cold).

Plug light	● - - Green	Base light	☀ - - Flashing red/green
<b>Temperature abnormal</b>			

5. A fully discharged pack with an internal temperature in the normal range will fully charge in 70 mins (between 32°F/0°C and 113°F/45°C). Heavily cycled battery packs may take longer to charge completely.
6. If the light indicators does not come on at all, check that the battery pack is fully seated into the bay. Remove the pack and reinsert. If the problem persists, contact an authorized Snow Joe® + Sun Joe® dealer or call the Snow Joe® + Sun Joe® customer service center at 1-866-SNOWJOE (1-866-766-9563) for assistance.
7. When charging is complete, remove the battery from the charger by pulling the push lock button and sliding the battery backward to unlock it from the charger (Fig. 16).

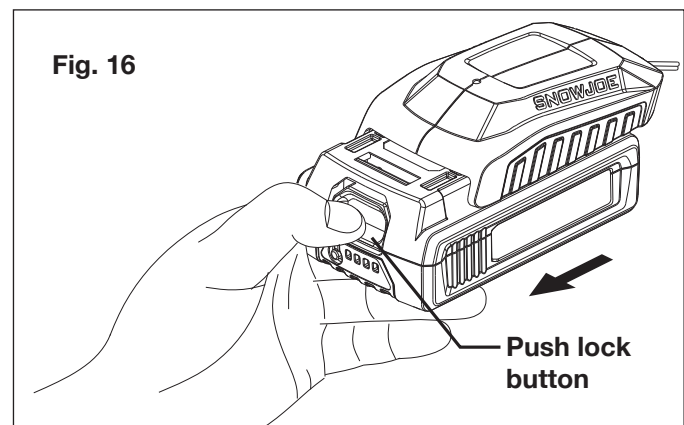

- Timely recharging of the battery will help prolong the battery's life. You must recharge the battery pack when you notice a drop in the equipment's power.

**IMPORTANT!** Never allow the battery pack to become fully discharged as this will cause irreversible damage to the battery.

## Charging a Hot or Cold Battery Pack

A red and green flashing indicator light on the charger base indicates that the battery pack temperature is outside the charging range. Once the pack is within the acceptable range, normal charging will take place and the red light will be continuous. Hot or cold battery packs may take longer to charge.

Lithium-Ion Charging Status		
Battery Pack Temperature	Charger Base Indicator Light	Charging Status
Too hot	Flashing	Not charging
Normal range	Red	Normal charging
Too cold	Flashing	Not charging

## Operation

### Starting and Stopping

**CAUTION!** Starting, stopping, and restarting an electric motor repeatedly within a few seconds can generate a great deal of heat and damage the motor. To protect the life of your cordless chain saw, always wait at least five seconds after stopping before restarting the saw.

**WARNING!** Be sure that the chain is not in contact with any object when you start the motor.

**WARNING!** Keep hands away from chain. Keep hands on handles. Do not overreach.

A good, firm grip on the tool using both hands will help you maintain control. Maintain a firm grip by place your right hand on the rear handle and left hand on the front handle with thumbs and fingers encircling the respective handles. A firm grip combined with proper positioning of the handle against your body will help you maintain control of the saw. Do not let go of the saw while it is in operation.

**WARNING!** Do not operate the cordless chain saw in a tree, on a ladder, or on a scaffold. Using the tool under such circumstances is extremely dangerous.

**CAUTION!** The chain will continue to run for several seconds after turning off the tool.

Do not use the chain saw under wet conditions. Use extreme caution when cutting small brush, saplings, or limbs under

tension because slender and tense material may catch the saw and be whipped toward you, pull you off balance, or spring back.

Do not use the chain saw to cut vines and/or small underbrush.

**WARNING!** Do not let familiarity with this type of tool prevent you from taking all necessary precautions. Remember that a careless fraction of a second is sufficient to inflict serious injury.

**WARNING!** Do not cut trees near electrical wires.

**WARNING!** Failure to lubricate the chain will cause damage to the bar and chain. Use only a good quality bar and chain oil designed specifically for use with chain saws.

**NOTE:** It is normal for oil to seep from the saw when not in use. To prevent seepage, empty the oil tank after each use. When storing the unit for a long period of time (3 months or longer), be sure the chain is lightly lubricated; this will prevent rust on the chain and bar sprocket.

- Prior to each cutting session, run through the daily checklist (see pg. 20).
- Insert the battery in the battery compartment (Fig. 17).

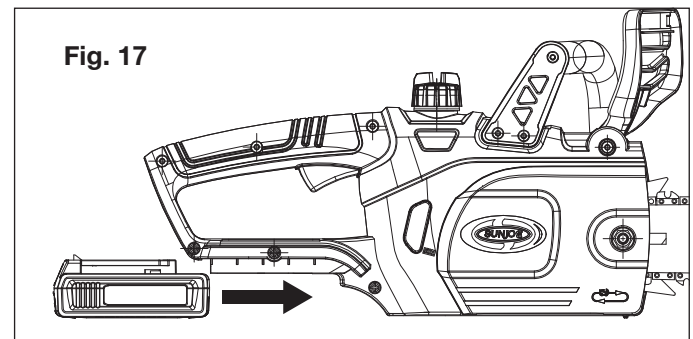

- To turn the tool on, hold the chain saw firmly with both hands. Press the safety lock button, then push the trigger switch. When the chain saw is running, you can release the safety lock button (Fig. 18).

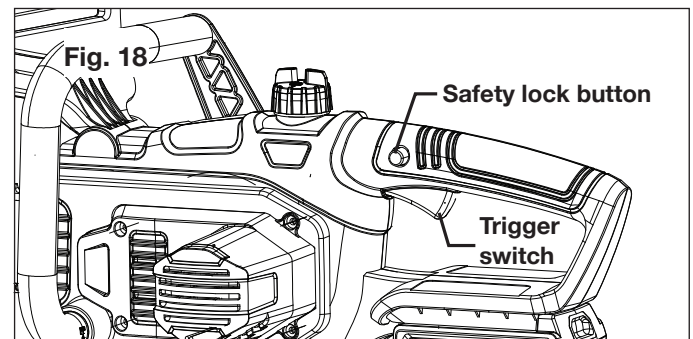

- To turn the tool off, simply release the trigger switch.

**NOTE:** Do not press the trigger switch until you are ready to make a cut.

# Operating Tips

**⚠️ WARNING!** For your safety and that of others:

1. Do not use the machine without reading the instructions carefully. Become acquainted with the controls and the proper use of the machine. Learn how to stop the machine quickly.
2. Keep in mind that the operator or user is responsible for accidents or hazards occurring to other people or their property.
3. Always wear suitable clothing when using the machine. Wear anti-vibration gloves and other personal protective equipment.

All the above-mentioned precautions do not, however, guarantee the prevention of certain risks – i.e. Raynaud's phenomenon or Carpal tunnel syndrome. For operators who use this machine for prolonged periods, it is therefore recommended to have periodic checkups on their hands and fingers. If any of the above mentioned symptoms should appear, please contact a physician immediately.

4. Work only in daylight or good artificial light.
5. Take utmost care when working near metal fences.
6. Take care not to hit the bar hard against foreign objects or flying debris caused by the movement of the chain.
7. Stop the motor and remove the battery from its compartment:
  - Whenever you leave the machine unattended;
  - Before cleaning, checking or servicing the machine;
  - After striking a foreign object. Inspect the machine for any damage and make repairs before restarting it again;
  - If the machine begins to vibrate abnormally, immediately look for the cause of the vibrations and have the machine inspected at an authorized Snow Joe® + Sun Joe® dealer or call the Snow Joe® + Sun Joe® customer service center at 1-866-SNOWJOE (1-866-766-9563) for assistance.
  - When the machine is not in use.

**IMPORTANT!** Always remember that an incorrectly used chain saw may disturb others and have a serious impact on the environment.

To respect people and the environment:

- Avoid using the machine in environments or at times of the day when it may disturb others.
- Scrupulously comply with local regulations and provisions for the disposal of waste materials after sawing.
- Scrupulously comply with local regulations and provisions for the disposal of oils, damaged parts or any elements which have a strong impact on the environment.

- A certain amount of chain lubricating oil is released into the environment when the machine is running, so only use biodegradable oils made specifically for this use.
- To avoid the risk of fire, do not leave the machine with the engine hot on leaves or dry grass.

**⚠️ WARNING!** It takes specific training to use the machine for felling and delimiting.

## Checks During Work

- **Checking the chain tension**

The chain tends to stretch gradually as you work, so you need to check its tension frequently.

**IMPORTANT!** During the first period of use (or after replacing the chain), the chain tension must be checked more frequently due to settling of the chain.

**⚠️ WARNING!** Never work with the chain loose, as it can be hazardous if the chain slips out of its guides.

To adjust the chain tension, follow the instructions in "Adjusting the Chain Tension" on page 11.

- **Checking the oil delivery**

**IMPORTANT!** Never use the machine without lubrication! You can check the oil level in the tank through the transparent gauge. Make sure you fill up the oil tank every time you use the machine. For best results, use only a good quality bar and chain oil designed specifically for use with chain saws.

**⚠️ WARNING!** Make sure the bar and the chain are in place when you check the oil delivery.

Start the motor and check if the chain oil is delivered as shown below (Fig. 19).

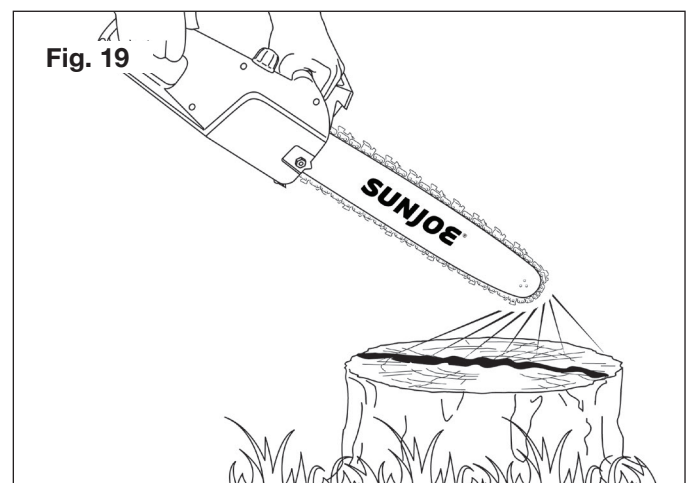

## Proper Cutting Stance

- Weight should be balanced with both feet on solid ground.
- Keep your left arm and elbow locked in a "straight arm" position to withstand any kickback force (Fig. 20).

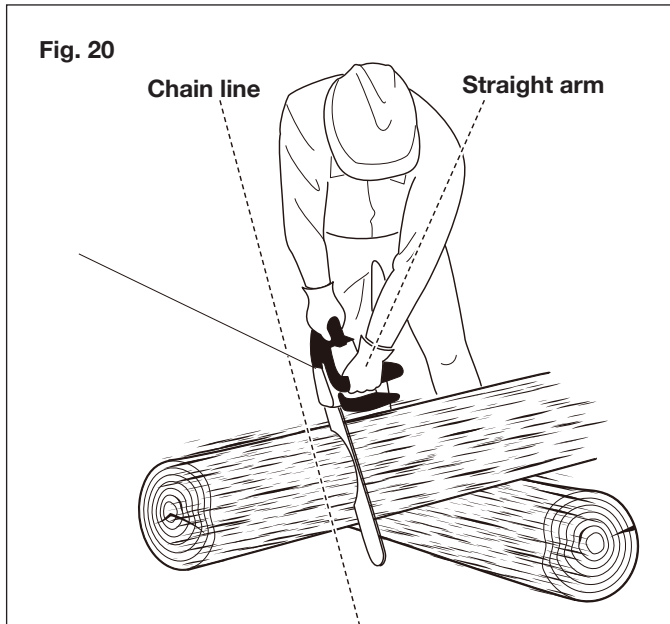

- Your body should always be to the left of the chain line.

## Basic Cutting Procedures

**⚠️ WARNING!** This unit is designed for trimming small branches and limbs up to recommended 7.9 in. (20 cm), not to exceed a max cut of 9.5 in. (24 cm) in diameter depending on type of wood. Practice cutting a few small limbs using the following technique to get the "feel" of using the saw before you begin a major sawing operation.

- Take the proper stance in front of the wood with the saw turned off (Fig. 20).
- Squeeze the trigger and let the chain accelerate to full speed before entering the cut.
- Hold the saw with both hands firmly. Always keep your left hand on the front handle and your right hand on the rear handle so that your body is to the left of the chain line.
- Keep the unit running the entire time you are cutting, maintaining a steady speed.
- Let the chain do the work; exert only light downward pressure. If you force the cut, damage to the bar, chain, or unit can result.
- Do not put the pressure on the saw at the end of the cut.
- Always cut with both feet on solid ground to prevent falling.
- Do not cut above chest height since it is difficult to control kickback forces with a saw held high.

## Cutting Techniques

Before felling or delimiting for the first time, practice sawing logs on the ground or on trestles, so that you can get familiar with the machine and the most suitable sawing techniques.

**⚠️ WARNING!** Always hold the machine with both hands when sawing.

**⚠️ WARNING!** Stop the motor immediately if the chain stops during sawing. Beware of kickback, which can occur if the bar contacts an obstacle.

### • Felling a tree

- When bucking and felling are performed by two or more people at the same time, the felling operation should be separated from the bucking operation by a distance of at least twice the height of the tree being felled. Trees should not be felled in a manner that would endanger any person, strike any utility line or cause any property damage. If the tree does make contact with any utility line, the company should be notified immediately.
- The chain saw operator should keep on the uphill side of the terrain as the tree is likely to roll or slide downhill after it is felled.
- An escape path should be planned and cleared as necessary before cuts are started. The escape path should extend back and diagonally to the rear of the expected line of fall as illustrated (Fig. 21).

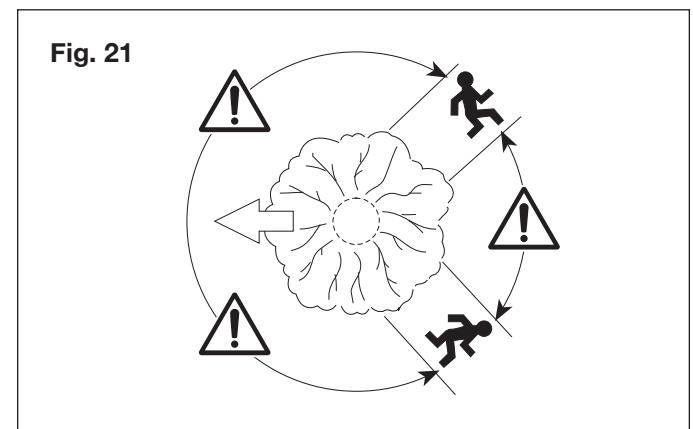

**iv)** Before felling is started, consider the natural lean of the tree, the location of larger branches and the wind direction to help you judge which way the tree will fall.

**v)** Remove dirt, stones, loose bark, nails, staples and wire from the tree.

### • Notching undercut

Make the notch 1/3 the diameter of the tree, perpendicular to the direction of falls as illustrated (Fig. 22).



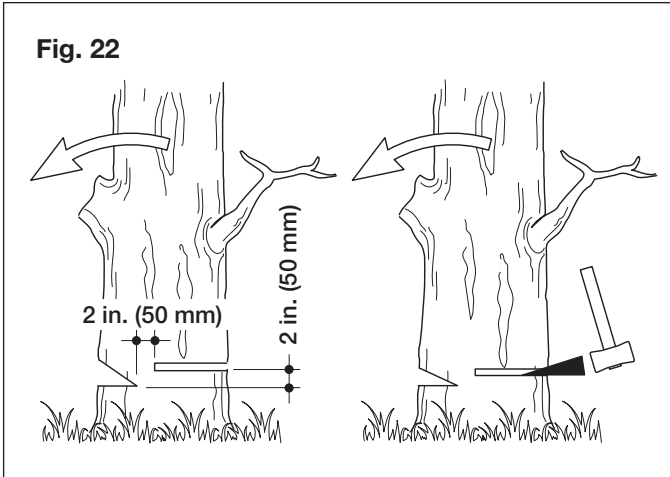

Fig. 22

Make the lower horizontal notching cut first.

This will help to avoid pinching either the saw chain or the guide bar when the second notch is made.

- **Felling back cut**

- i) Make the felling back cut at least 2 in. (50 mm) higher than the horizontal notching cut as illustrated (Fig. 22). Keep the felling back cut parallel to the horizontal notching cut. Strategically position the felling back cut so that enough wood is left to act as a hinge. The hinge wood keeps the tree from twisting and falling in the wrong direction. Do not cut through the hinge.
- ii) As the felling gets close to the hinge, the tree should begin to fall. If there is any chance that the tree may not fall in the desired direction or it may rock back and bind the saw chain, stop cutting before the felling back cut is complete and use wedges of wood, plastic or aluminium to open the cut and drop the tree along the desired line of fall.
- iii) When the tree begins to fall, remove the chain saw from the cut, stop the motor, put the chain saw down, then use the retreat path planned. Be alert for overhead limbs falling and watch your footing.

- **Limbing**

Limbing is the process in which branches are removed from a fallen tree. When limbing, leave larger lower limbs to support the log off the ground. Remove the small limbs in one cut as illustrated (Fig. 23). Branches under tension should be cut from the bottom up to avoid binding the chain saw.

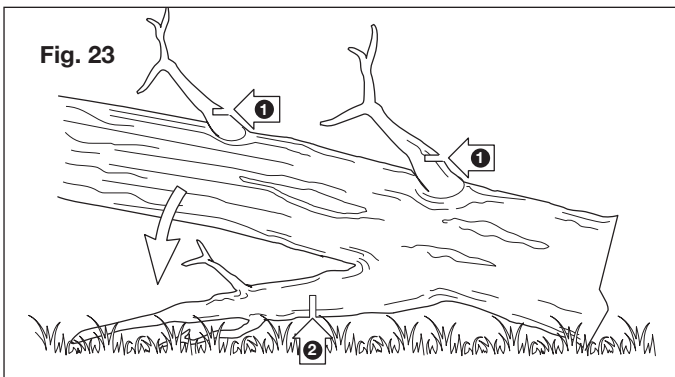

Fig. 23

**⚠️ WARNING!** Pay special attention to where the branches are lying on the ground and recognize the following risks: 1). the branches may be under tension; 2). the direction in which the branch will fall may differ from that anticipated; 3). the tree may be unstable after the branch has been cut.

- **Bucking a log**

**⚠️ WARNING!** Do not buck logs that are larger than the maximum cutting thickness.

Bucking is the process in which a log is cut into lengths. It is important to make sure your footing is firm and your weight is evenly distributed on both feet. When possible, the log should be raised and supported by the use of limbs, logs, or chocks. Follow these simple directions for easy cutting:

- When the log is supported along its entire length as illustrated (Fig. 24A), cut from the top (overbuck).

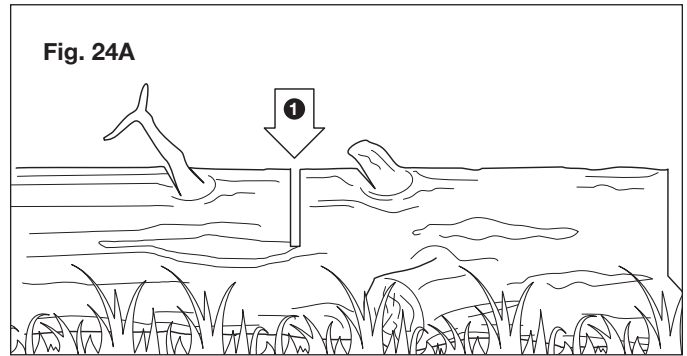

Fig. 24A

- When the log is supported on one end (Fig. 24B), cut 1/3 the diameter from the underside (underbuck). Then make the finishing cut by overbucking to meet the first cut.

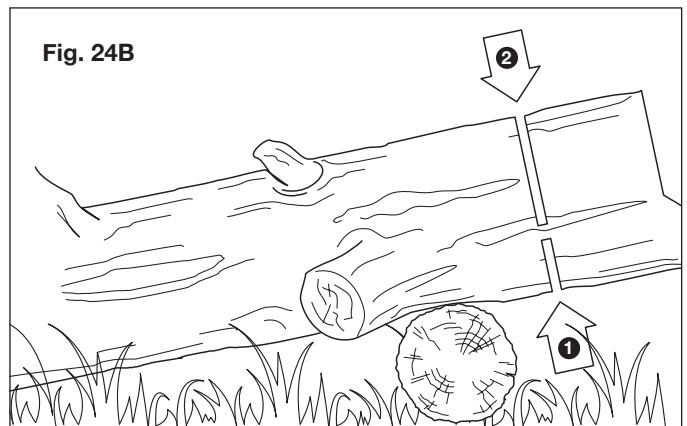
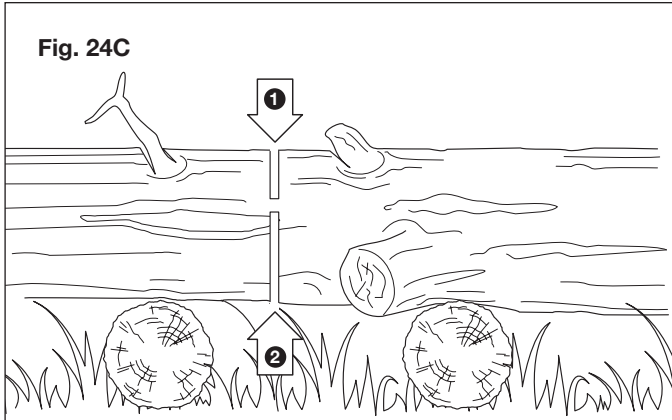
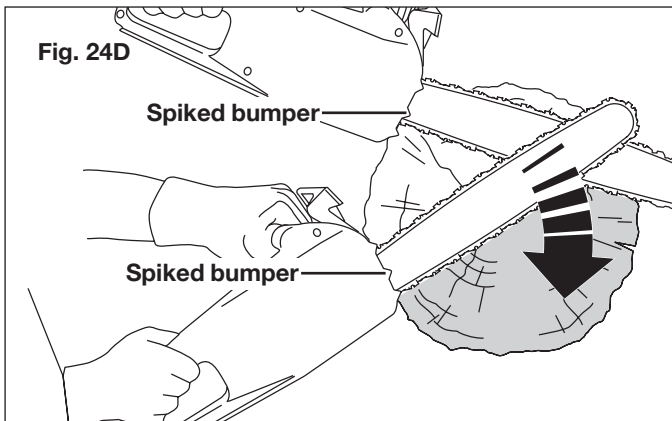

Fig. 24B

- When the log is supported on both ends (Fig. 24C), cut 1/3 the diameter from the top (overbuck). Then make the finishing cut by underbucking the lower 2/3 to meet the first cut.



- It is easier to saw a log using the spiked bumper (Fig. 24D).
  - Dig the spiked bumper into the log and use it as a pivot. Cut with an arched motion to make the bar penetrate the wood.
  - Repeat several times if necessary, changing the point where you plant the spiked bumper.



- When bucking on a slope, always stand on the uphill side of the log. When cutting through the log, maintain control by releasing the cutting pressure near the end of the cut without relaxing your grip on the chain saw handles. Do not let the chain contact the ground.

After completing the cut, wait for the saw chain to stop before you move the chain saw. Always stop the motor before moving from tree to tree.

## Maintenance

Please contact an authorized Snow Joe® + Sun Joe® dealer or call the Snow Joe® + Sun Joe® customer service center at 1-866-SNOWJOE (1-866-766-9563) for all maintenance operations not foreseen in this manual. Any operation performed in an unauthorized service center or by unqualified personnel will completely invalidate the warranty.

**⚠ WARNING!** For your safety and that of others:

- Correct maintenance is essential to maintain the original efficiency and safety of the machine over time.
- Keep all nuts, bolts, and screws tight to be sure the equipment is in safe working condition.
- Never use the machine with worn or damaged parts. Damaged parts are to be replaced and never repaired.
- Only use original Snow Joe® + Sun Joe® replacement parts. Parts that are not of the same quality can seriously damage the equipment, compromise safety, and invalidate the warranty.

**⚠ WARNING!** Always remove the battery before performing any adjustments, maintenance, or repairs to your cordless chain saw.

- Use protective gloves when handling the bar and chain.
- Keep the bar encased in its sheath, except when working directly on the bar or the chain.
- Never dispose of oils or other polluting materials in unauthorized places.

## Motor Cooling

To avoid overheating and damage to the motor, always keep the cooling air vents clean and free of sawdust and debris.

## Chain Tension

Check the chain tension before using the saw when the chain is cold. The correct tension of a cold chain is when there is no slack on the underside of the guide bar; the chain is snug, but you can rotate it by hand without binding.

During normal saw operation, the temperature of the chain will increase. The drive links of a correctly tensioned warm chain will hang approximately 0.050 in. (1.25 mm) out of the bar groove (Fig. 25). Be aware that a chain tensioned while warm, may be too tight upon cooling. Check the “cold tension” before next use. The chain must be re-tensioned whenever the flats on the drive links hang out of the bar groove (Fig. 25).

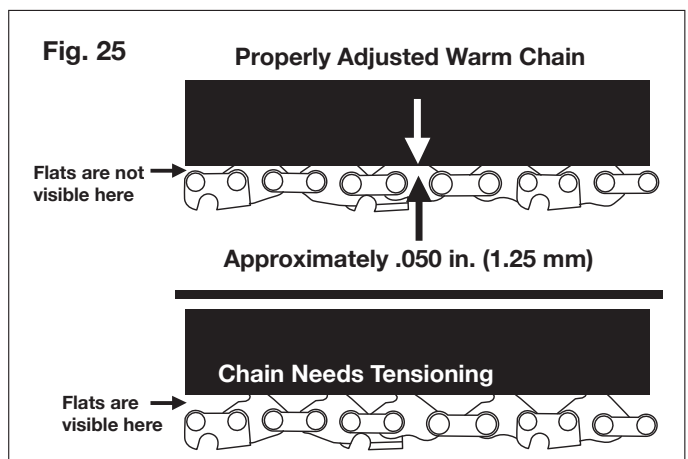

**NOTE:** A new chain tends to stretch. Check the chain tension frequently and re-tension as needed.

## Chain Sharpening

To maintain optimal blade sharpness and peak performance, Sun Joe recommends model 24V-CSSHRP-LTE Cordless Chain Saw Sharpener, available on sunjoe.com, by phone at 1-866-SNOWJOE (1-866-766-9563),

**⚠️ WARNING!** To ensure that the saw works safely and efficiently, it is essential that the cutting components are well-sharpened. **It is highly recommended to replace the chain once it loses its ability to cut cleanly and safely.** It is possible, however, to sharpen the existing chain if the sharpening is carefully performed. Any work on the chain and bar requires specific experience and special tools. For safety purposes, we recommend you contact an authorized Snow Joe® + Sun Joe® dealer or call the Snow Joe® + Sun Joe® customer service center at 1-866-SNOWJOE (1-866-766-9563).

Sharpening is necessary when:

- The sawdust looks like dust;
- Cutting becomes more difficult;
- The cut is not straight;
- Vibrations increase.

An authorized service center will sharpen the chain using the right tools to ensure minimum removal of material and even sharpness on all the cutting edges.

If you sharpen the chain yourself, use special round-section files with the right diameter depending on the type of chain (see “Chain Maintenance Table” pg. 21). You need a certain amount of skill and experience to avoid damaging the cutting edges.

Sharpen the chain as follows (Fig. 26):

- Secure the bar firmly, with the chain mounted, in a suitable vise.
- Tighten the chain if it is loose.
- Mount the file in the guide and then insert it in the tooth at a constant angle from the cutting edge.
- Sharpen in a forward motion a few times and repeat this on all the cutting edges facing the same way (right or left).
- To move the chain forward, use a screwdriver.
- Turn the bar over in the vise and repeat on all the other cutting edges.
- Check that the depth limiter tooth does not stick out farther than the inspection tool and file any projecting parts with a flat file, rounding off the edges (Fig. 26).
- After sharpening, remove all traces of filing and dust

and lubricate the chain in an oil bath. Replace the chain whenever:

- The length of the cutting edges decreases to 5 mm or less;
- There is too much play between the links and the rivets.

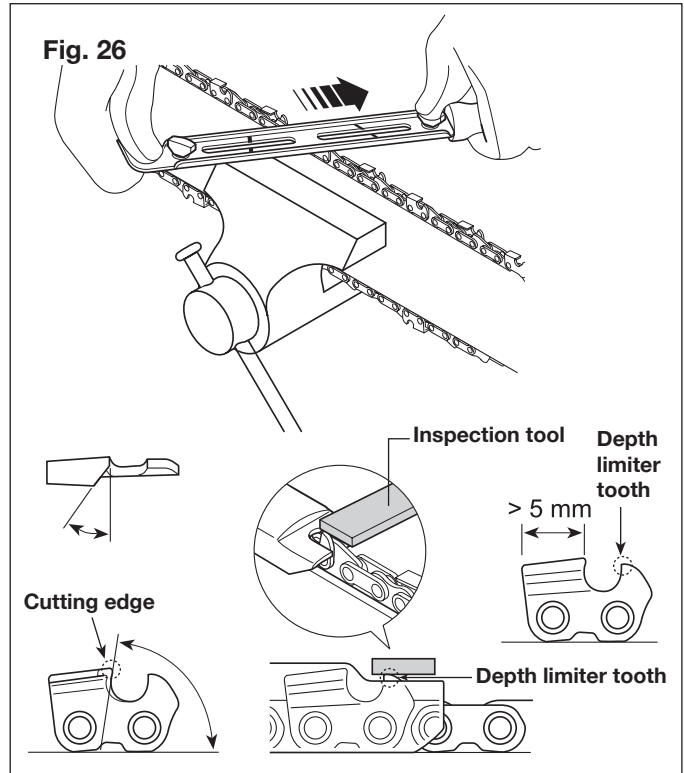

## Guide Bar Maintenance

When the guide bar shows signs of wear, turn it over on the saw to distribute the wear for maximum bar life. Feathering or burring of the bar rails is a normal process of bar wear. You should smooth such faults with a file as soon as they occur.

Replace a bar with any of the following faults:

- wear inside the bar rails permitting the chain to lay over sideways
- bent guide bar
- cracked or broken rails
- spread rails

Turn the saw over, check the underside of the guide bar, and make sure that the lubrication holes and chain groove are free from impurities.

You can purchase replacement parts for your Sun Joe® 20ViONLTE-CS10-RM cordless chain saw by ordering online at sunjoe.com or, to order by phone, contact Snow Joe® + Sun Joe® customer service at 1-866-SNOWJOE (1-866-766-9563).

## Chain Sprocket

Regularly check the condition of the sprocket and replace it when wear exceeds 0.5 mm (Fig. 27).

Do not mount a new chain with a worn sprocket or vice-versa.

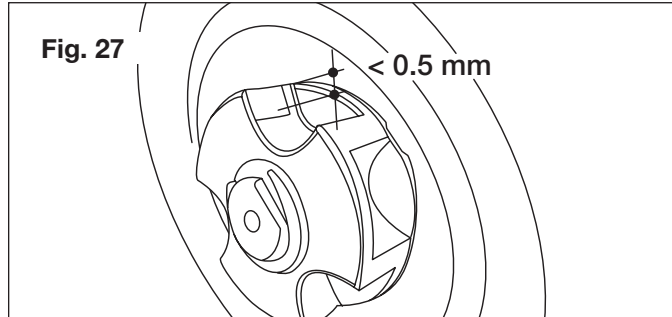

## Troubleshooting

### Troubleshooting Tips

Most difficulties are easy to fix. Consult the troubleshooting table for common problems and their solutions. If you continue to experience problems or need repairs beyond these minor adjustments, please call 1-866-SNOWJOE (1-866-766-9563) for assistance.

**⚠️ WARNING!** Always remove the battery before performing any adjustments, maintenance, or repairs to your cordless chain saw.

### Troubleshooting Table

Problems	Corrective Action
The saw motor fails to start	<ul style="list-style-type: none"> <li>• Make sure that the battery is inserted correctly</li> <li>• Check charge status and recharge the battery</li> </ul>
The saw stops during operation	<ul style="list-style-type: none"> <li>• Make sure that the battery is inserted correctly</li> <li>• Check charge status and recharge the battery</li> </ul>
The saw runs, but the chain speed is low	<ul style="list-style-type: none"> <li>• The chain is too tight; re-tension.</li> </ul>
Bar and chain running hot and smoking	<ul style="list-style-type: none"> <li>• The chain tension is too tight; re-tension.</li> <li>• The chain oil tank is empty; refill.</li> <li>• The lubrication holes are plugged; clean them out.</li> </ul>
The saw motor runs, but the chain is not turning	<ul style="list-style-type: none"> <li>• The chain tension is too tight; re-tension.</li> <li>• The guide bar or chain is damaged; inspect and replace the damaged part.</li> </ul>

## Daily Checklist, Cleaning and Storage

### Daily Checklist

To help maintain your cordless chain saw for optimum performance, we recommend you complete this checklist prior to each work session.

**⚠️ WARNING!** Do not insert the battery until you have completed all of the daily checks.

- Inspect for any visible damage to the chain, guide bar, or motor housing.
- Inspect the oil port and guide bar rails and clean them to remove any debris.
- Check the chain tension.
- Check the chain teeth for sharpness.
- Check the bar and chain oil level; fill with only new chain oil specifically formulated for chain saws.

**NOTE:** If you notice anything unusual, such as a vibration or odd sound, shut the saw OFF immediately. Remove the battery and check the saw for any damage.

If you cannot find the cause of the problem or are uncertain what to do, then have the saw inspected by an authorized Snow Joe® + Sun Joe® dealer or call the Snow Joe® + Sun Joe® customer service center at 1-866-SNOWJOE (1-866-766-9563) before using it.

**⚠️ CAUTION!**

- Remove the battery and wait at least five minutes for the saw to cool before servicing or storing your unit.
- If you drop the saw, carefully inspect it for damage. If the guide bar is bent, the housing is cracked, the handle is broken, or if you see any other condition that may affect the saw's operation, **DO NOT USE** the tool. Instead, have it serviced at an authorized Snow Joe® + Sun Joe® dealer or call the Snow Joe® + Sun Joe® customer service center at 1-866-SNOWJOE (1-866-766-9563).

### Cleaning

Use only mild soap and a damp cloth to clean the cordless chain saw. Never let any liquid get inside the motor housing and **NEVER** immerse any part of the saw housing in liquid.

### Storage

- Ensure that the guide bar cover is in place when storing.
- Do not store cordless chain saw near chemicals, such as fertilizers or other harsh solvents. Do not expose the plastic parts of the unit to brake fluids, gasoline, petroleum-based products, penetrating oils, or the like. These products are often highly corrosive and may cause

permanent damage, weaken, or destroy the plastic parts of your unit.

- When not in use, your machine should be stored indoors in a dry and high or locked-up place, out of the reach of children.

## Battery Caution + Disposal

Always dispose of your battery pack according to federal, state, and local regulations. Contact a recycling agency in your area for recycling locations.

**⚠ CAUTION!** Even discharged battery packs contain some energy. Before disposing, use electrical tape to cover the terminals to prevent the battery pack from shorting, which could cause a fire or explosion.

**⚠ WARNING!** To reduce the risk of injury or explosion, never burn or incinerate a battery pack even if it is damaged, dead, or completely discharged. When burned, toxic fumes and materials are emitted into the surrounding atmosphere.

1. Batteries vary according to device. Consult your manual for specific information.
2. Install only new batteries of the same type in your product (where applicable).
3. Failure to insert batteries in the correct polarity, as indicated in the battery compartment or manual, may shorten the life of the batteries or cause batteries to leak.
4. Do not mix old and new batteries.
5. Do not mix Alkaline, Standard (Carbon-Zinc), or Rechargeable (Nickel Cadmium, Nickel Metal Hydride, or Lithium-Ion) batteries.
6. Do not dispose of batteries in fire.

7. Batteries should be recycled or disposed of as per state and local guidelines.

## Service and Support

If your Sun Joe® 20ViONLTE-CS10-RM cordless chain saw requires service or maintenance, please call 1-866-SNOWJOE (1-866-766-9563) for assistance.

## Model and Serial Numbers

When contacting the company, reordering parts, or arranging service from an authorized dealer, you will need to provide the model and serial numbers, which can be found on the decal located on the housing of the unit. Copy these numbers into the space provided below.

Record the following numbers from the housing or handle of your new product:	
Model #:	2   0   V   i   O   N   L   T   E   -   C   S   1   0   -   R   M
Serial #:	

## Chain Maintenance Table

Drive Links	Chain Pitch		Chain Gauge		File Diameter	
	inches	mm	inches	mm	inches	mm
40	3/8	9.5	0.050	1.3	5/32	4

# iCHRG20

## Federal Communications Commission (FCC)

 **WARNING!** Any changes or modifications to this unit not expressly approved by the party responsible for compliance could void the user's authority to operate the equipment.

### **Class B device:**

**NOTE:** This equipment has been tested and found to comply with the limits for a Class B digital device, pursuant to part 15 of the FCC Rules.

These limits are designed to provide reasonable protection against harmful interference in a residential installation.

This equipment generates, uses and can radiate radio frequency energy and, if not installed and used in accordance with the instructions, may cause harmful interference to radio communications.





However, there is no guarantee that interference will not occur in a particular installation.

If this equipment does cause harmful interference to radio or television reception, which can be determined by turning the equipment off and on, the user is encouraged to try to correct the interference by one or more of the following measures:

- Reorient or relocate the receiving antenna.
- Increase the separation between the equipment and receiver.
- Connect the equipment into an outlet on a circuit different from that to which the receiver is connected.
- Consult the dealer or an experienced radio/TV technician for help.

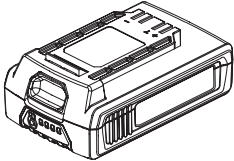
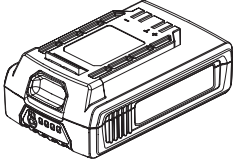
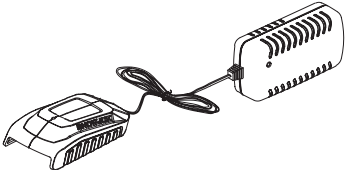
# Optional Accessories

**⚠️ WARNING!** ALWAYS use only authorized Snow Joe® + Sun Joe® replacement parts and accessories. NEVER use replacement parts or accessories that are not intended for use with this saw. Contact Snow Joe® + Sun Joe® if you are unsure whether it is safe to use a particular replacement part or accessory with your saw. The use of any other attachment or accessory can be dangerous and could cause injury or mechanical damage.

Accessories	Item	Model
	EcoSharp® LITE 20 V 2.0 Ah Lithium-iON Battery Charging Time Max: 70 min Battery Run Time Max: 12 min	iBAT20-LTE
	EcoSharp® LITE 20 V 2.5 Ah Lithium-iON Battery Charging Time Max: 90 min Battery Run Time Max: 15 min	iBAT20-LT
	EcoSharp® 20 V Lithium-iON battery charger	iCHRG20
	Sun Joe® 10-inch replacement bar	SWJ-10BAR
	Sun Joe® 10-inch replacement chain	SWJ-10CHAIN
	Bar and chain oil	SWJ-OIL Sold online at <a href="http://sunjoe.com">sunjoe.com</a> or you can purchase equivalent bar and chain oil at your local hardware store

**NOTE:** Accessories are subject to change without any obligation on the part of Snow Joe® + Sun Joe® to provide notice of such changes. Accessories can be ordered online at [sunjoe.com](http://sunjoe.com) or via phone by contacting the Snow Joe® + Sun Joe® customer service center at 1-866-SNOWJOE (1-866-766-9563).





## NOTES

---

---

---

---

---

---

---

---

---

---

---

---

---

---

---

---

---

---

---

---

---

---

---

---

---

---

---

---

---





## SNOW JOE® + SUN JOE® REFURBISHED GOODS WARRANTY

### GENERAL CONDITIONS:

Snow Joe® + Sun Joe® operating under Snow Joe®, LLC warrants this refurbished product to the original purchaser for 90 days against defects in material or workmanship when used for normal residential purposes. If a replacement part or product is needed, it will be sent free of charge to the original purchaser except as noted below.

The duration of this warranty applies only if the product is put to personal use around the household. It is the owner's responsibility to correctly perform all maintenance and minor adjustments explained in the owner's manual.

### HOW TO OBTAIN YOUR REPLACEMENT PART OR PRODUCT:

To obtain a replacement part or product, please visit [snowjoe.com/help](http://snowjoe.com/help) or email us at [help@snowjoe.com](mailto:help@snowjoe.com) for instructions. Please be sure to register your unit beforehand to speed up this process. Certain products may require a serial number, typically found on the decal affixed to the housing or guard of your product. All products require a valid proof of purchase.

### EXCLUSIONS:

- Wearing parts like belts, augers, chains and tines are not covered under this warranty. Wearing parts can be purchased at [snowjoe.com](http://snowjoe.com) or by calling 1-866-SNOWJOE (1-866-766-9563).
- Batteries are covered in full for 90-days from the date of purchase.

Snow Joe® + Sun Joe® may from time to time change the design of its products. Nothing contained in this warranty shall be construed as obligating Snow Joe® + Sun Joe® to incorporate such design changes into previously manufactured products, nor shall such changes be construed as an admission that previous designs were defective.

This warranty is intended to cover product defects only. Snow Joe®, LLC is not liable for indirect, incidental or consequential damages in connection with the use or misuse of the Snow Joe® + Sun Joe® products covered by this warranty. This warranty does not cover any cost or expense incurred by the purchaser in providing substitute equipment or service during reasonable periods of malfunction or non-use of this product while waiting for a replacement part or unit under this warranty. Some states do not allow exclusions of incidental or consequential damages so the above exclusions may not apply in all states. This warranty may give you specific legal rights in your state.

### HOW TO REACH US:

We're here to help Monday through Friday from 9AM to 7PM EST and Saturday and Sunday 9AM to 4PM. You can reach us at 1-866-SNOWJOE (1 866-766-9563), online at [snowjoe.com](http://snowjoe.com), via email at [help@snowjoe.com](mailto:help@snowjoe.com) or tweet us @snowjoe.

### EXPORTS:

Customers who have purchased Snow Joe® + Sun Joe® products exported from the United States and Canada should contact their Snow Joe® + Sun Joe® distributor (dealer) to obtain information applicable to your country, province or state. If for any reason, you are not satisfied with the distributor's service, or if you have difficulty obtaining warranty information, contact your Snow Joe® + Sun Joe® seller. If in the event your efforts are unsatisfactory, please reach out to us directly.



[sunjoe.com](http://sunjoe.com)